

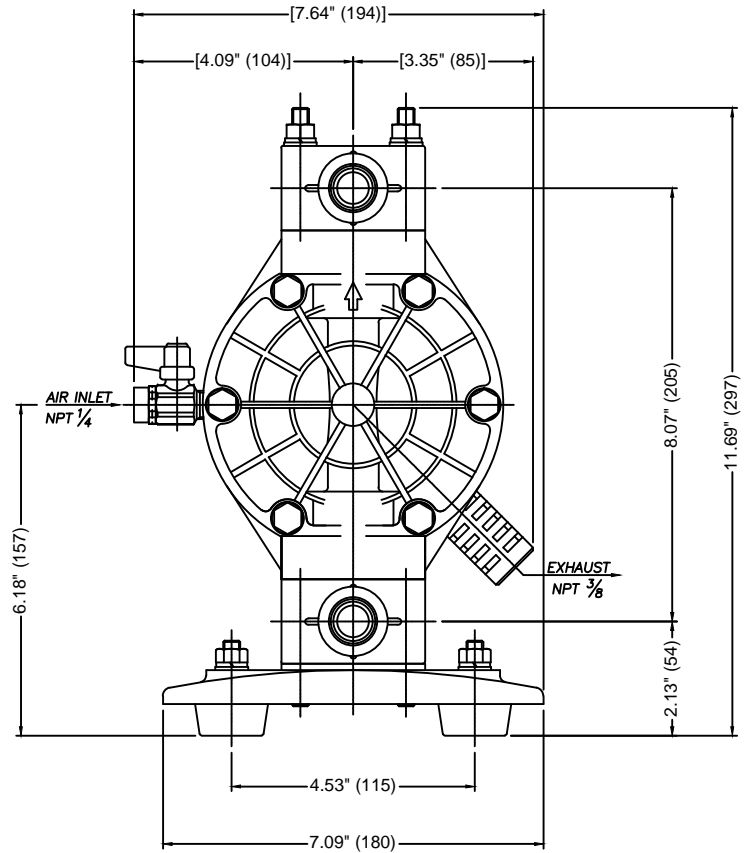

REVISIONS			
REV	DESCRIPTION	DATE	APPROVED
A	RELEASED	9/30/2015	CJC

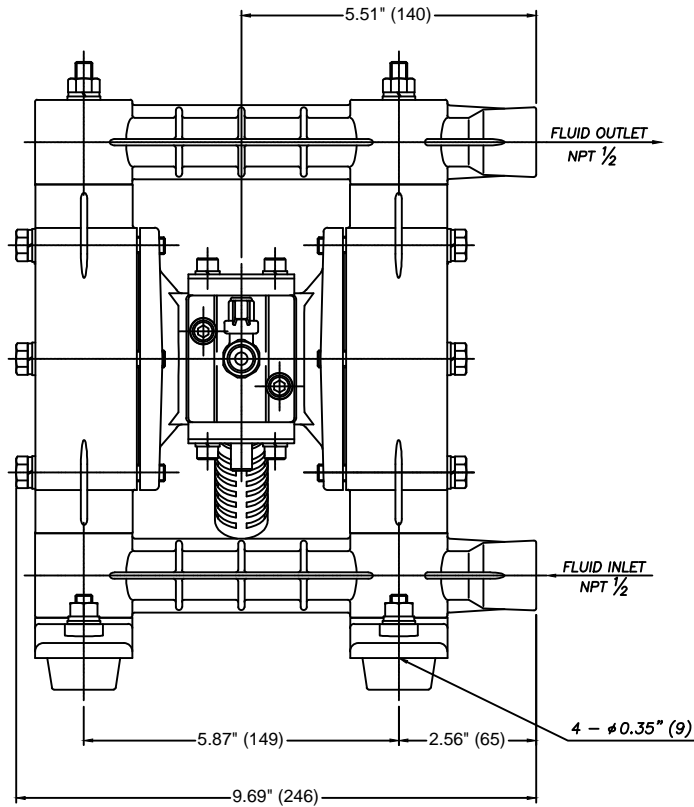

NOTES:
1. SOME FEATURES MAY VARY SLIGHTLY.

PROPRIETARY THIS DRAWING CONTAINS CONFIDENTIAL INFORMATION PROPRIETARY TO IWAKI AMERICA. IT MUST NOT BE REPRODUCED OR FORWARDED TO OTHERS OR USED IN ANY OTHER WAY, IN WHOLE OR IN PART, UNLESS AUTHORIZED IN WRITING BY IWAKI AMERICA.		TOLERANCES DIMENSIONS IN INCHES UNLESS OTHERWISE NOTED X = .050 .XX = .010 .XXX = .005 DEBURR AND BREAK ALL SHARP EDGES		 www.IwakiAir.com		5 Boynton Rd. Hopping Brook Park Holliston, MA 01746 (508) 429-1440	
MATERIAL		POM/PTFE		BY		TK	
DATE		9/4/2015		DATE		9/25/2015	
APPROVED		CJC		SCALE:		FULL	
DWG NO.		TC-X00112		DESCRIPTION		TC-X150DT	
REV		A		THIRD ANGLE PROJECTION		SHEET: 1 OF 1	

Materials of Construction	
PUMP BODY MATERIAL	PPG
	C=CR
	N=NBR
DIAPHRAGM MATERIAL	T=PTFE
	H=TPEE
	S=TPD

REVISIONS			
REV	DESCRIPTION	DATE	APPROVED
A	RELEASED	9/30/2015	CJC

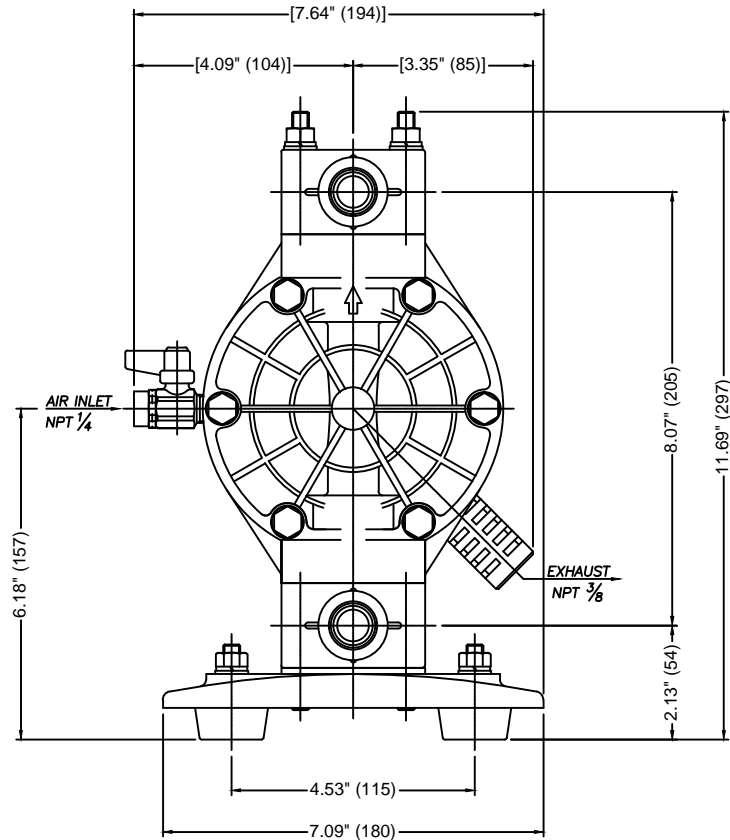
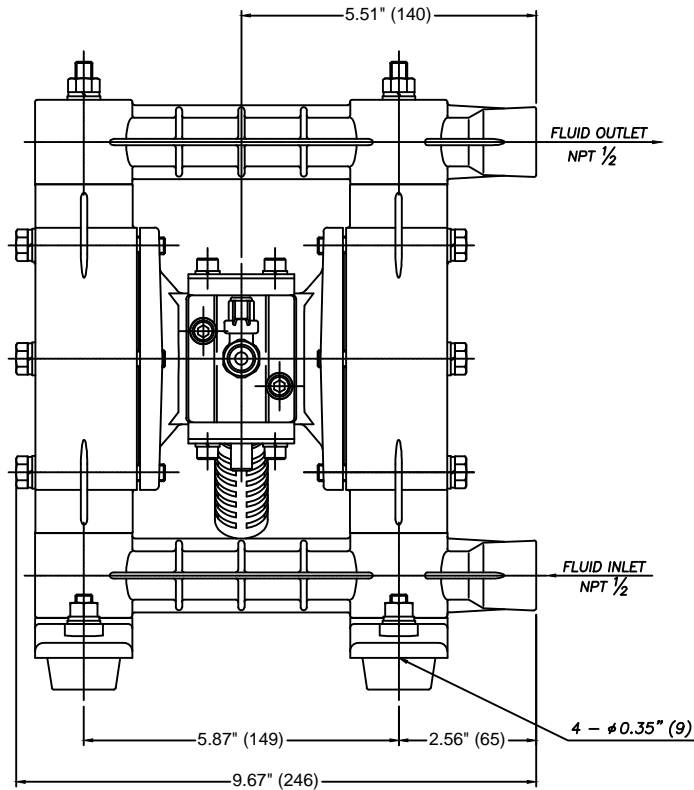

NOTES:
1. SOME FEATURES MAY VARY SLIGHTLY.

PROPRIETARY THIS DRAWING CONTAINS CONFIDENTIAL INFORMATION PROPRIETARY TO IWAKI AMERICA. IT MUST NOT BE REPRODUCED OR FORWARDED TO OTHERS OR USED IN ANY OTHER WAY, IN WHOLE OR IN PART, UNLESS AUTHORIZED IN WRITING BY IWAKI AMERICA.		TOLERANCES DIMENSIONS IN INCHES UNLESS OTHERWISE NOTED X = .050 .XX = .010 .XXX = .005 DEBURR AND BREAK ALL SHARP EDGES		 www.IwakiAir.com		5 Boynton Rd. Hopping Brook Park Holliston, MA 01746 (508) 429-1440	
MATERIAL		SEE CHART		SCALE: FULL		THIRD ANGLE PROJECTION	
BY	DATE	SIZE	DWG NO.	DESCRIPTION		REV	
TK	9/4/2015	B	TC-X00113	TC-X150P		A	
APPROVED	DATE	SCALE: FULL		THIRD ANGLE PROJECTION		SHEET: 1 OF 1	
CJC	9/25/2015						