

Exploded View Drawing and Parts List

Model: **TC-X800PS-FLA**

Model Number: **1P00084MN**

Serial Number:

Service Code:

The part list and exploded view drawing as attached below indicate the full list of parts for the above mentioned pump model.

When ordering parts take care to select the correct model pump and required parts. Also be aware that models may change over time as improvements are made so cross-referencing the pumps serial number assembly date and service code are also recommended.

If you require specific spare parts you can also use this form to place your order.

For more information specific to your pump please refer to the pumps Service Book and Operation Manual available separately.

Please contact your Pump Distributor directly for more information.

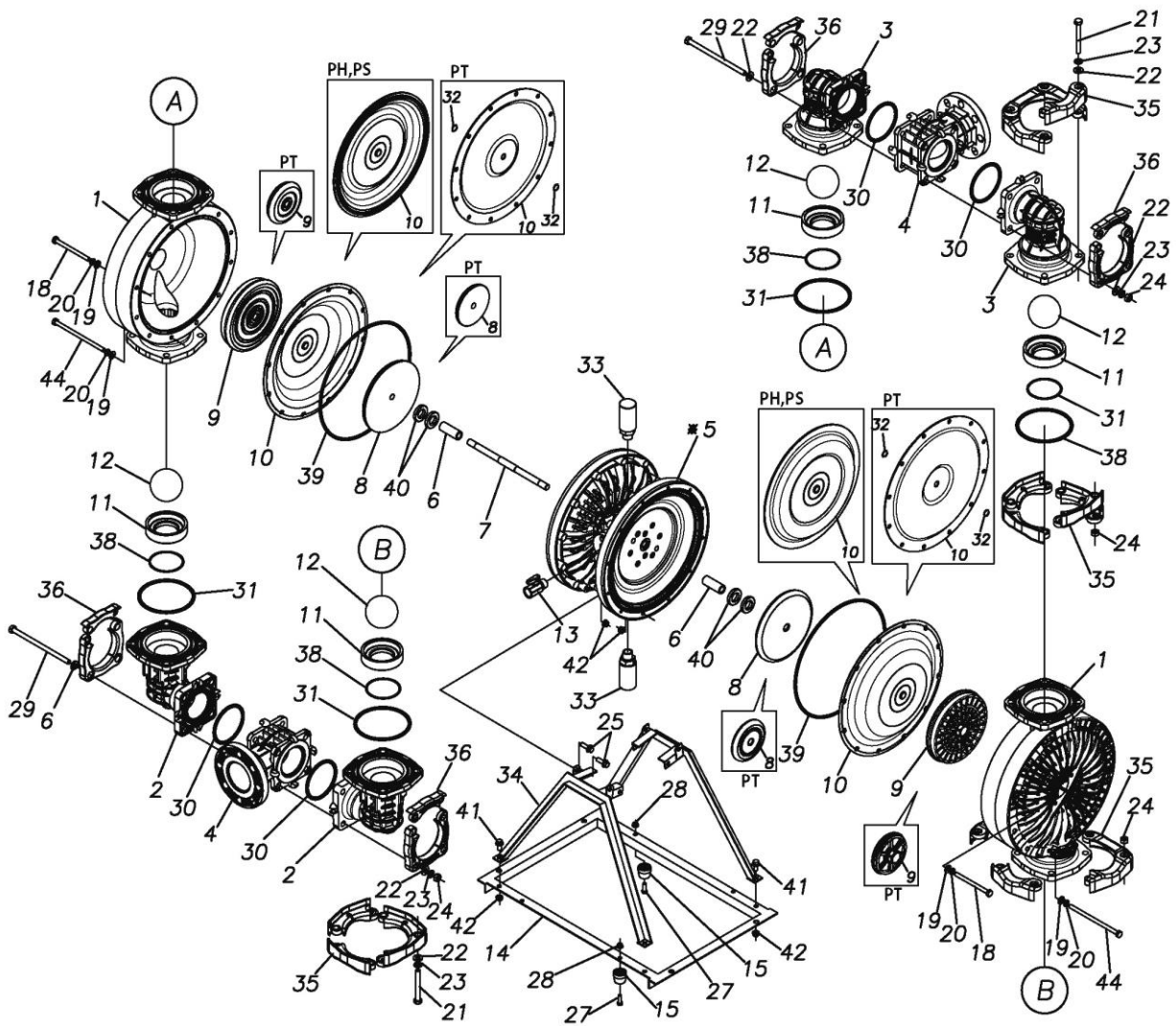

* 5

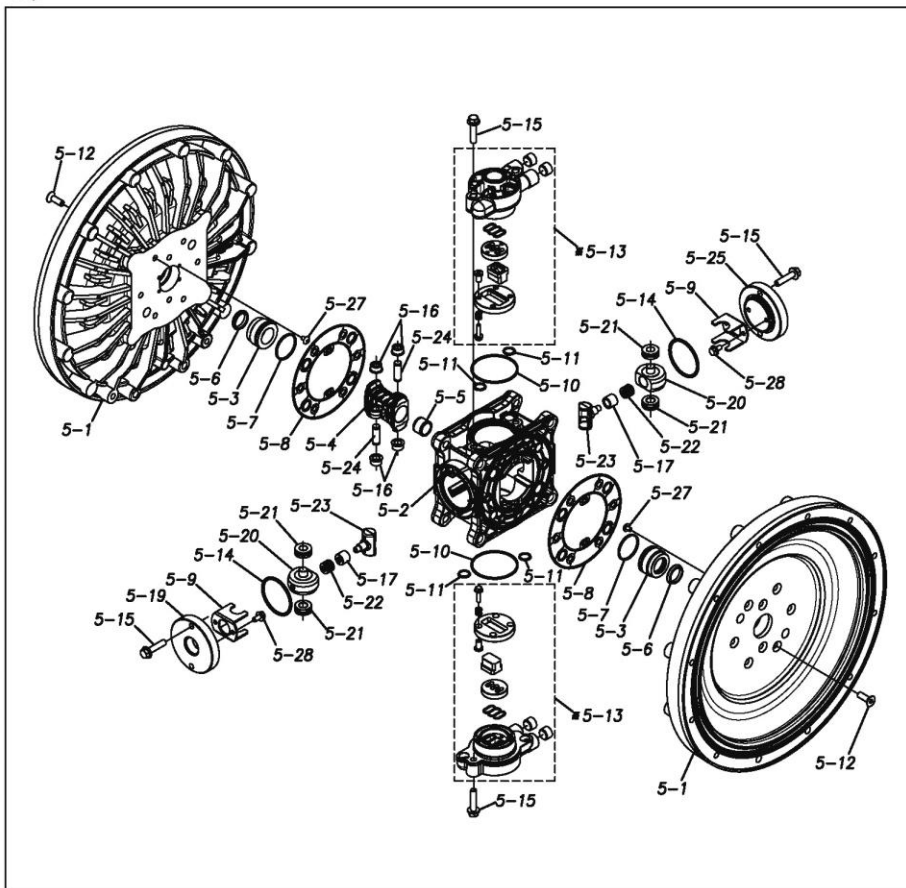

* 5-13

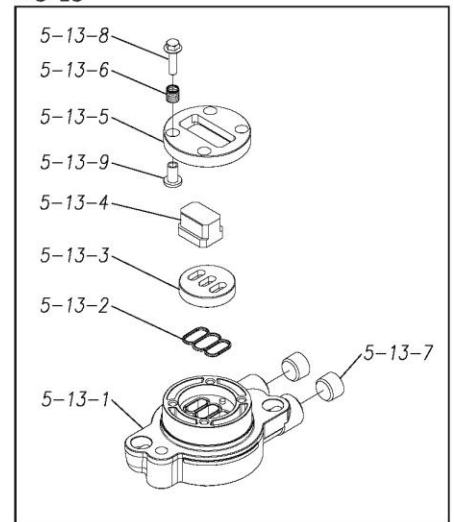

Ref.No.	Parts No.	Description	Parts Component	Remark	Order Qty
1	1P20023PM	OUT CHAMBER	2		
2	1P20024PM	IN MANIFOLD	2		
3	1P20025PM	OUT MANIFOLD	2		
4	1P20026PM	CENTER MANIFOLD	2		
5	1P10001MN	BODY ASSEMBLY	1		
5-1	1P30009MM	AIR CHAMBER	2	The parts of #5 are available with a set as [1P10001MN:BODY ASSEMBLY]. This is also available individually.	
5-2	1M30001MM	BODY	1		
5-3	1P30001MM	BEARING CENTER ROD	2		
5-4	1M30011MM	SHUTTLE	1		
5-5	1M30012MM	BEARING SHUTTLE	1		
5-6	9S2BA0025	PACKING	2		
5-7	9S1BS0036	O RING S-36	2		
5-8	1M30027MB	PACKING BODY	2		
5-9	1M30004MM	BRACKET BEARING	2		
5-10	9S1BG0065	O RING G-65	2		
5-11	9S1BP0014	O RING P-14	4		
5-12	9B5410835	BOLT M8 × 35	16		
5-13	1M10002MP	VALVE BODY ASSEMBLY	2		The parts of #5-13 are available with a set as [1M10002MP:VALVE BODY ASSEMBLY]. This is also available individually.
5-13-1	1M30002MP	VALVE BODY	2		
5-13-2	1M30016MB	PACKING VALVE	2		
5-13-3	1M30014MM	SEAT SLIDE VALVE	2		
5-13-4	1M30013MM	SLIDE VALVE	2		
5-13-5	1M30015MM	GUIDE SLIDE VALVE	2		
5-13-6	1M30020MM	SPRING	8		
5-13-7	1H30043MB	PLUG	4		
5-13-8	9B2110520	BOLT M5 × 20	8		
5-13-9	1M30019MM	GUIDE SPRING	8		
5-14	9S1BG0055	O RING G-55	2	The parts of #5 are available with a set as [1P10001MN:BODY ASSEMBLY]. This is also available individually.	
5-15	9B2110835	BOLT M8 × 35	8		
5-16	1M30006MM	BEARING PIN	4		
5-17	1M30017MM	BEARING ARM	2		
5-19	1M30010MN	CAP BODY IN	1		
5-20	1M30005MM	CASE SPRING	2		
5-21	1M30007MM	BEARING CASE SPRING	4		
5-22	1M30008MM	SPRING	2		
5-23	1M30003MB	ARM	2		
5-24	1M30023MM	PIN SHUTTLE	2		
5-25	1M30009MM	CAP BODY	1		
5-27	9T6125008	SCREW M5 × 8	8		
5-28	9B2110612	BOLT M6 × 12	4		
6	1P30002MM	SPACER CENTER ROD	2		
7	1P20021MM	CENTER ROD	1		
8	1P20028MM	CENTER DISK	2		
9	1P20029PB	CENTER DISK	2		
10	1P20038SB	DIAPHRAGM	2		
11	1P20042PM	VALVE SEAT	4		
12	1P20003EB	BALL	4		
13	1M90001MN	BALL VALVE	1		
14	1P30004MB	BASE	1		
15	1E30070MB	RUBBER FEET	4		
18	9B1291003	BOLT M10 × 130	20		
19	9W1211000	PLAIN WASHER M10	24		

Ref.No.	Parts No.	Description	Parts Component	Remark	Order Qty
20	9W2211000	SPRING LOCK WASHER M10	24		
21	9B1291200	BOLT M12 × 100	16		
22	9W1211200	PLAIN WASHER M12	32		
23	9W2211200	SPRING LOCK WASHER M12	24		
24	9N1211200	NUT M12	24		
25	9B2211030	BOLT M10 × 30	4		
27	9B1210825	BOLT M8 × 25	4		
28	9N2210800	NUT M8	4		
29	9B1291203	BOLT M12 × 220	8		
30	9S1EP0110	O RING P-110	4		
31	9S1EG0090	O RING G-90	4		
33	1H90003MK	SILENCER	2		
34	1P30003MB	STAND BODY	2		
35	1P30010MB	PROTECTOR A	32		
36	1P30011MB	PROTECTOR B	16		
38	9S1EP0150	O RING P-150	4		
40	1P30012MB	CUSHION CENTER DISK	4		
41	9B2211020	BOLT M10 × 20	4		
42	9N2211000	NUT M10	8		
44	9B1291013	BOLT M10 × 190	4		

memo